

# INTERNATIONAL EUROVAULT

## **Feature-packed Burglary and Fire-Resistant Safe**

- High security construction, using high density aggregate compound
- 2" thick barrier walls and door slab
- Security Installation Platform (SIP) bolts to floor and safe offering supreme anti-theft security
- 3-Way bolt work with 1 1/4" chrome-plated bolts
- Auto lock bolt detent keeps bolts extended when door is closed & retracted when door is open
- Auto firing passive relocker protects locks during forced entry attempt
- High tensile strength drill resistant hardplate
- Stainless steel polished fascia panel
- Adjustable shelves
- U.L. Listed Group II combination lock with satin finish dial, dial ring & handle
- High security key lock
- One hour fire rating at 1500° incorporating expandable fire gasket surrounding door jam

A burglary/fire resistant safe is an affordable solution when you need to protect papers and valuables from fire and burglary. The high density composite door and body offers excellent burglary protection, and one-hour fire protection. A 2" door slab, composite body, dual locking function with bolt control and a unique anchoring, pry-resistant system offers superior anti-theft security.

The International Eurovault offers many features of high security safe construction without the price! Available in five sizes, it is excellent for both residential and small business use.



# International Eurovault

## Specifications

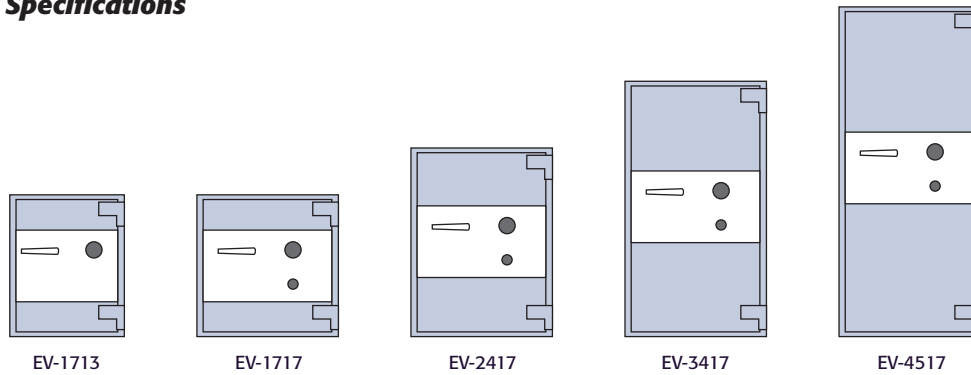

**Dimensions and Weights** (Add 2" to exterior depth for hinge projection. Add 2" to exterior depth for removeable handle projection.)

Model	Interior H x W x D (in)	Exterior H x W x D (in)	Weight (lbs)	Capacity (cu ft)	Shelves
EV-1713	17 x 13 x 13	21 x 17 x 19.5	380	1.6	1
EV-1717	17 x 17 x 17	21 x 21 x 23.5	510	2.8	1
EV-2417	24 x 17 x 17	28 x 21 x 23.5	625	4.2	2
EV-3417	34 x 17 x 17	38 x 21 x 23.5	810	5.6	2
EV-4517	45 x 17 x 17	49 x 21 x 23.5	1,084	7.5	3

## Door Swing Dimensions

Model	Dimensions (in)		
	A	B	C
EV-1713	13	31	28
EV-1717	17	42.5	38.25
EV-2417	17	42.5	38.25
EV-3417	17	42.5	38.25
EV-4517	17	42.5	38.25

## Door Swing Projections

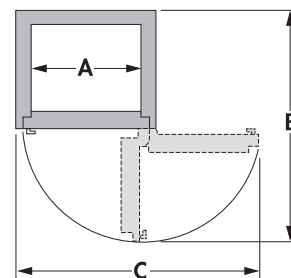

## Security Installation Platform

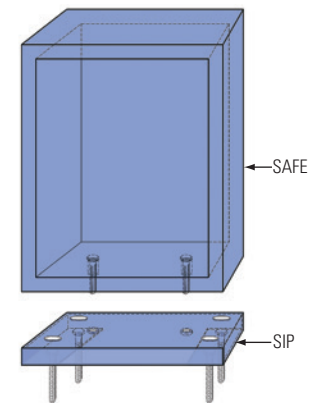

Electronic digital pushbutton locks with operational features such as programmable combinations, multiple user interface, time delay, and auditing are available and can be configured with electronic lock devices from LaGard, Kaba Mas, Sargent & Greenleaf, or Millennium Globaloks.

Each International Eurovault comes with the revolutionary Security Installation Platform (SIP), an exclusive innovation that ensures accurate and secure installation. A four-point anchoring system and pry-resistant design deters attempts to remove safes by force.



## Distributed By:

**SOCALSAFE**  
Since 1915

510 West Washington Blvd.  
Montebello, CA 90640  
(323) 724-5880 Telephone  
(800) 334-6060 Toll Free  
(323) 727-0236 Fax  
www.socalsafe.com

All specifications are approximate and subject to change without notice.

©2014 Southern California Safe Company. All Rights Reserved