

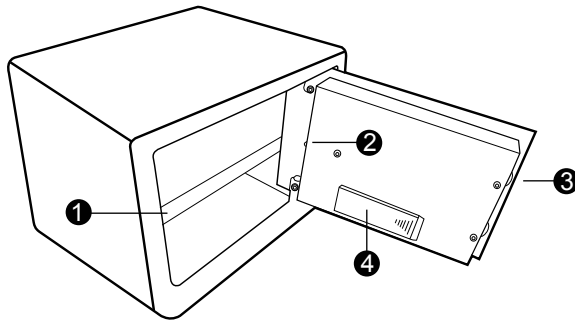

# User Manual for Biometric Fingerprint Lock Safe

## Parts of the Safe



### Parts of the Safe

- |                    |                        |
|--------------------|------------------------|
| 1. Removable Shelf | 3. Bolts               |
| 2. Initialization  | 4. Battery Compartment |

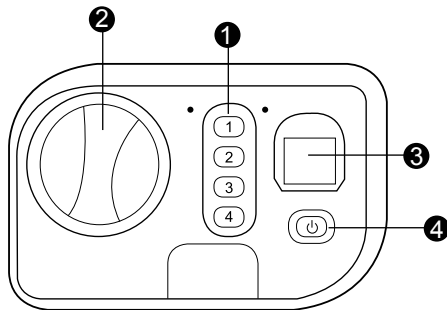

### Parts of the Control Panel

- |            |                        |
|------------|------------------------|
| 1. Key Pad | 3. Fingerprint Scanner |
| 2. Knob    | 4. Confirmation Key    |

## Set Up

Remove special access keys from the inside of safe before set up and keep them in a safe place

Factory settings have no stored fingerprints

Factory default pin code is "1234"

For security purposes, change the factory default code as soon as possible

## Batteries

- To replace batteries open safe door and remove battery cover
- Only use four AA alkaline batteries and be sure to note the polarity of the battery

### LOW BATTERY INDICATOR

If the red indicator light is flashing or is consistently on, this indicates that the batteries are low. Open safe by using the supplied emergency key

## Registering a Fingerprint

- Press and release the initialization button on the inside of the safe door
- Immediately place finger on scanner, you will hear two beeps and one long beep. Remove fingerprint from scanner
- Registration of fingerprint is now complete
- To add a fingerprint repeat steps 1 through 3

### Note

Three short beeps will be heard if fingerprint was NOT registered successfully. Repeat steps 1-3

### For Accurate and Consistent Fingerprint Scanning

- Use scanner in low light conditions
- Use the thumb finger
- Place and hold finger firmly on the scanner
- Each user should register 2-3 different fingerprints

## Opening the Door with Fingerprint

- Press the confirmation key until the scanner illuminates red
- Place finger on scanner until red illumination ceases
- The green indicator light will flash and you will hear one beep, indicating a successful scan
- Turn the knob clockwise and open the safe

### Note

Three short beeps indicate an unsuccessful fingerprint scan, repeat steps 1-3

## Closing and Locking Door

Close the door and turn the knob counter clockwise

### Note

Be sure the door is closed completely

## Initial Numeric Pin Code

- Press and hold number "1" key until green indicator light is on
- Input pin code and press the confirmation key. You will hear one beep  
Note: For initial setup factory default code is "1234"
- Enter the new pin code (four to eight digits) and press confirmation key
- Re-enter the new code and press the confirmation key. You will hear one beep indicating that the new code is saved
- Registration of pin code is now complete

### Note

If you hear 3 short beeps this indicates that the pin was not registered successfully, repeat steps 1-4

Safe only retains one pin number

## Opening the Door with Pin code

- Enter pin code and press the confirmation key
- One beep and the scanner flashes green indicates that you have entered the correct pin
- Turn the knob clockwise and open the safe

### Note

Three short beep indicates incorrect pin code, repeat steps 1-3

## Closing and Locking Door

Close the door and turn the knob counter clockwise

### Note

Be sure the door is closed completely

## Changing the Pin Code

- Press and hold number "1" key until green indicator light is on
- Enter the old pin code and press the confirmation key
- When a beep is heard enter the new pin code (four to eight digits) and press the confirmation key
- Enter new pin code and press the confirmation key again. If a long beep is heard, the adjustment was successful.

### Note

If you hear 3 short beeps this indicates that pin was not successful, repeat steps 1-4

Safe only retains one pin number



# User Manual for Biometric Fingerprint Lock Safe

## To Delete All Fingerprints and Pin Code

1. Open safe door by either of the three methods; fingerprint, pin code or emergency key
2. Press and hold down the initialization key
3. The finger scanner flashes green twelve times and a beep is heard to indicate all fingerprints and pin code is deleted
4. Once the flashing ceases release the initialization button
5. The safe is now in its original factory setting

### Note

Any fingerprint can open safe door

Factory default pin code is "1234"

## Opening the Safe with Key

1. In emergency situations where number pad and/or fingerprint module is disabled, use emergency key to open the safe
2. Use supplied hex tool to remove the badge bolts on the safe door
3. Place key in the emergency lock and turn counterclockwise
4. Turn the knob clockwise to open safe door

### Note

DO NOT place emergency keys inside of safe

## Care and Maintenance

- If necessary use a damp cloth to clean the safe. DO NOT use chemicals or cleaning agents
- Keep liquids away from the control panel. Spills on the control panel will cause damage and possibly electric shock
- Properly secure the safe to prevent it from falling and causing damage or injury
- For security purposes, change the factory default code as soon as possible
- DO NOT over stuff the contents of the safe or you can damage the motor mechanism or the contents
- DO NOT disassemble the product. For all repairs and maintenance, contact authorized service centers or distributor
- DO NOT place emergency keys inside of safe

## Mounting

The safe may be mounted to a wall or through the floor. When mounting to a wall, be sure of the load bearing so as to hold the weight of the safe and the contents. Failure to do so could result in the safe falling and damaging property and or people.

Suggested 12mm socket wrench tool and drill bits

### Mounting Through The Bottom Of The Safe

1. Check the floor for what type it is (wood, tile and or concrete)
2. Get the appropriate anchors for the type of floor you have
3. Check location on the floor for concealed wires or pipes
4. Mark the floor to drill your anchor
5. Drill the appropriate size hole for the anchors you have
6. Mount the safe and make sure it is securely mounted

DO NOT mount safe without anchoring to the wall behind the safe!

### Mounting Through The Back Of The Safe

1. Check the wall or cabinet for structural soundness
2. For safety, have someone help you to hold the safe during mounting
3. Check location for concealed wires or pipes
4. Mark the surface to drill holes for the anchors you will be using
5. Drill the appropriate size holes for the anchors you are using
6. While having someone hold the unit, anchor the safe to the wall
7. Test the strength of the mounted safe so it will not fall off the wall or cabinet

DO NOT mount safe without anchoring to the wall behind the safe!

## Biometric Safe Warranty

1. BARSKA warrants the Biometric Safe against original defects in material and/or workmanship under normal use for a period of twelve (12) months from the date product is received by purchaser.
2. This Warranty is limited to original purchaser and is not transferable.
3. This Warranty applies only to products purchased in the United States.
4. BARSKA will examine and test returned product and repair or replace defective part(s) or units with new part(s) or a new unit if necessary within the warranty period. Purchaser is required to remit \$50.00 to BARSKA for return shipping and handling at time product is returned.
5. If repair is required after warranty period expiration, purchaser will be charged for replacement parts and return shipping.
6. Purchaser must contact BARSKA at 1.909.445.8168 to request a Returned Merchandise Authorization (RMA) number. The RMA number must appear on the outside of the shipping package. Product must be packed carefully and sturdily in its original packaging to prevent damage in transit and returned freight pre-paid to:

BARSKA  
Repair Department  
1721 Wright Avenue  
La Verne, CA 91750

What is NOT covered by this Warranty?

1. Damage caused by improper installation or maintenance.
2. Damage from misuse, abuse, accident (such as dropping), fire, flood, or acts of nature.
3. Damage from service or repairs other than those performed by BARSKA.
4. Labor, cost and shipping charges for the removal and replacement of defective parts beyond the initial twelve-month warranty period.
5. All transportation and shipping charges.
6. Removing or altering the seal on the rear of the front part of the safe under any circumstances will automatically void the warranty.